

ELECTRONIC DIGITAL CALIPER

CE

03.04.0487EEC



D4 06 07 60503 001

In accordance with the
European
Directive ROHS 2002/95/CE

● TECHNICAL SPECIFICATIONS

Measuring range:	0-150mm/0-6in, 0-200mm/0-8in, 0-300mm/0-12in.
Resolution:	0.01mm/0.0005in.
Accuracy:	A0.02mm/0.001in (<100mm). A0.03mm/0.001in (>100-200mm). A0.04mm/0.0015in (>200-300mm).
Repeatability:	0.01mm/0.0005in.
Max measuring speed:	1.5m/sec, 60in/sec.
Measuring system:	Linear capacitive measuring system.
Display:	LCD display.
Power:	One silver oxide battery 1.55V, type SR44. capacity: 180mAh.
Current:	<20 μ A
Working temperature:	5 BC-40 BC/41 to 104 degree F.
Influence of humidity:	Not important under 80% of relative humidity.

● NOMENCLATURE

- | | |
|--|-------------------------------|
| 1. Outside measuring faces | 2. Inside measuring faces |
| 3. Depth measuring blade | 4. Step measuring faces |
| 5. Beam | 6. Main scale |
| 7. Battery compartment lid | 8. Output connector |
| 9. Display(LCD) | 10. Slider clamp screw |
| 11. Thumb roller(depending on the model) | 12. Power ON/OFF switch |
| 13. ZERO switch | 14. Inch/mm conversion switch |

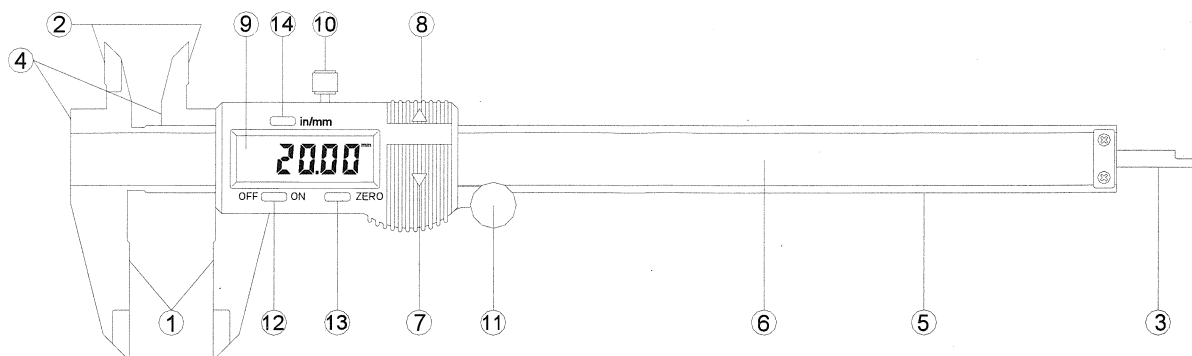

● APPLICATIONS

1. PREPARATIONS :

- (1).Slider can be removed only after the locking screw (No.10 item of the Nomenclature) is loosened.
- (2).Wipe clean all the measuring faces and caliper ber. No organic solutions are allowed.
- (3).Check to see if all the buttons, switches, and LCD display respond well.

2. BASIC MEASURING METHODS :

- (1).Loosen the locking screw.
- (2).Switch the unit on with a press on "ON" button. Then select the unit system needed by pressing Inch/Metric button. (Each time the button is pressed,inch and metric digits will be displayed alternatively).

(3).Apply normal measuring pressure on slider to close the external measuring jaws. Then press "zero" button to reset the display to zero.

A.Measurements of external dimensions.

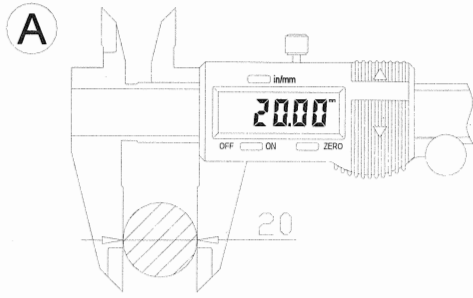

B.Measurements of internal dimensions.

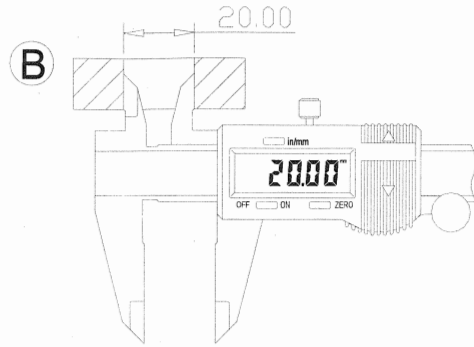

C.Measurements of steps.

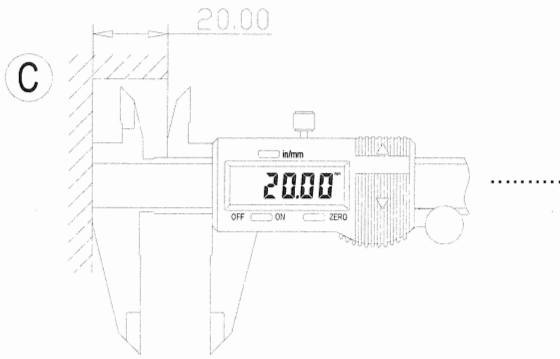

D.Measurements of depth.

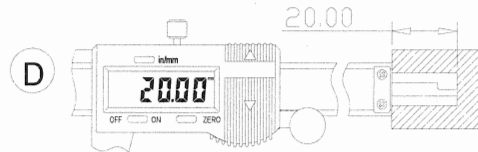

E.Differential method measurement (Application of zero setting)

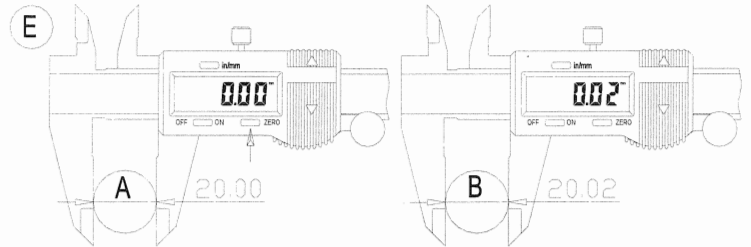

● MAINTENANCE INSTRUCTIONS

- 1.Keep the caliper clean and dry(Liquid can damage the slider).
- 2.Faces should be cleaned gently with cotton fabrics. Never use petrol, acetone and other organic solutions.
- 3.In order to save power, turn off the unit when caliper is going to stay idle for some time.
- 4.Never apply any electric pressure on any part of the caliper and never use an electronic pen for the fear of damaging its chip.
- 5.For other notes please refer to the conventional calipers.

● BATTERY REPLACEMENT

Flashing of digits shows a flat battery. Take off the battery cover in the direction shown by the arrow and replace the battery (positive side facing out).

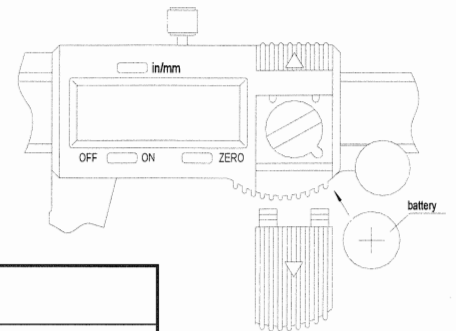

● TROUBLE SHOOTING

Failure	Cause	Measure
Five digits flash simultaneously ,about once per sec.	Battery voltage lower than 1.45V.	Replace the battery.
Display doesn't change when the slider is moved	Accidental trouble in circuit	Take out battery and eraset it after 30 sec.
Less accurate then specifi- -ed but with -in+0.1mm.	Dirt in the sensor.	Remove slider cover and its assembly, clean compressed air (5kg/cm).
No display on LCD	1.Battery in poor contact. 2.Battery voltage under 1.4V.	1.Remove battery cover and adjust the battery scat,keep good connection. 2.Replace battery.